

**SPEED POST**

E.MAIL: [cao@niam.res.in](mailto:cao@niam.res.in), [niasmao@gmail.com](mailto:niasmao@gmail.com).

TEL: 02112-254057/58

FAX: 02112-254056



**NATIONAL INSTITUTE OF ABIOTIC STRESS MANAGEMENT  
(ICAR)  
MALEGAON, BARAMATI, PUNE, MAHARASHTRA - 413115.**

**STANDARD BIDDING DOCUMENTS FOR  
ICAR**

**For LAB TABLE WITH BASINS  
DUE ON: 14.10.2015 AT 13:00 Hrs**

Date of Opening quotation on: 14.10.2015 at 14:30 Hrs.

**SENIOR ADMINISTRATIVE OFFICER  
NATIONAL INSTITUTE OF ABIOTIC STRESS MANAGEMENT (ICAR)  
MALEGAON, BARAMATI, PUNE,  
MAHARASHTRA-413115.**

**\*Please return this original document along with copy of bid after signing all the pages, failing which the same shall be ignored**

**\*\*Tender should be submitted in two bid system (technical bid+ financial bid)**

E-MAIL : [niasmao@gmail.com](mailto:niasmao@gmail.com)  
TEL: 02112-254057/58  
FAX: 02112-254056

NATIONAL INSTITUTE OF ABIOTIC STRESS MANAGEMENT  
MALEGAON, BARAMATI, PUNE, MAHARASHTRA - 413115

Quotation No: - F. No. 3-79/2015-16.

Dated: 24.09.2015.

To,

Dear Sir,

This institute require 4 no of lab tables with basin, technical bids for which will be opened at 02:30 hrs on 14.10.2015 and you are invited to submit your most competitive rate for the same. All the relevant details are given below.

- i. **DESCRIPTION : Lab table with basin**
  - ii. **QUANTITY: Four**
  - iii. **Guiding specification and other technical details:- Annexure 1**
  - iv. **Terms of delivery:**  
**Delivery at site viz.- NIASM, BARAMATI.**
  - v. Security Performances: To ensure due performance of the contract, performance security is to be furnished by the successful bidder for an amount of **10%** of the value of the goods as fixed by the competent Authority in the form of Account payee Demand draft, fixed deposit receipt Bankers cheque or Bank Guarantee in favour of the **ICAR UNIT NIASM, BARAMATI** within **10** days from the date of issue of purchase order. **EMD - Rs. 2,000/- must be submitted along with this Quotation/Limited Tender.**
  - vi. **Delivery period for goods: Within 30 days** from the date of the purchaser's signing the contract.
  - vii. Erection/installation and commissioning (if required, depending on the goods ordered) are to be completed within 10 days of delivery of the goods at site
  - viii. Terms of inspection by the Purchaser's representative
  - ix. Training of purchaser's operator(s) for operating the goods ordered (if applicable) As and if necessary:..... is/are to be trained for a period of .....weeks at purchaser's premises for successfully operating the goods purchased. The training shall be completed by.....
- viii. Price structure:**
- a) The tenderer shall quote for the complete requirement of goods and services and for the full quantity as shown against a serial number in the List of Requirements in **Annexure - 1**. Unless otherwise specified in **Annexure - 1**, the tenderers are, however, free *not* to quote against all the serial numbers mentioned in the list of requirements (in case there are more than one serial number in the list of requirements).
  - b) **The rates and prices quoted shall be in Indian Rupees only.**

- c) All duties, taxes and levies payable by the supplier under the contract shall be included in the quoted price. The purchaser will not pay any such duties, taxes and levies separately.
- d) The rates and prices quoted by the supplier shall remain firm and fixed during the currency of the contract and shall not be subject to variation on any account, whatsoever, including statutory variations, if any.

**ix. Receipt of goods and terms of payment:**

- a) Payment term for supply of goods, including erection/installation and commissioning (as and if applicable) :-**

Immediately on, receiving the goods at site, the purchaser will verify the quantities of the items supplied as specified in the delivery challan of the supplier and also check for any superficial damage etc. in the goods so supplied and issue a provisional receipt accordingly. If the goods supplied do not require erection/installation and commissioning at site, the purchaser, within three working days of issue of the provisional receipt, will issue acceptance certificate (of the goods) to the supplier, provided the goods supplied are acceptable in terms of the contract. However, if the goods supplied also need erection/installation and commissioning, the purchaser will issue acceptance certificate within two working days, after successful erection/installation and commissioning. The supplier will then send invoice along with the purchaser's acceptance certificate and other accompanying documents to the paying authority for payment. The paying will release the full payment to the supplier as due in terms of the contract, within fifteen working days of receipt of supplier's invoice, purchaser's receipt certificate and other accompanying documents, provided the same are in order.

- a) Payment Terms: In order to facilitate for speedy settlement of Payment, the firm is requested to furnish the following details as below-**

- 1. Name of the firm**
- 2. Name of the Bank**
- 3. IFSC Code of Bank**
- 4. Name of the Account & Account Number**
- 5. Branch Code**
- 6. Amount to be paid:**
- 7. E-mail address of the party:**

**C) Payment for training of purchaser's operator(s), if applicable.**

After release of payment to the supplier as per sub-para (a) above and after successful completion of training of the operator(s) in terms of the contract, the purchaser will immediately issue a certificate to this effect to the supplier. The supplier will thereafter send its invoice for training charges, along with the above certificate to the paying authority. The paying authority will release the payment to the supplier in terms of the contract within fifteen days of receipt of supplier's invoice provided the invoice and the accompanying documents are in order.

**PAYING AUTHORITY**

**THE DIRECTOR, NIASM, Baramati, Pune, Maharashtra-413115.**

**X) Liquidated Damage Clause:**

If any time during the performance of the contract, the supplier encounters conditions hindering timely delivery of the goods, duration of the same. After receipt of supplier's communication, the purchaser shall decide as to whether to cancel the contract for the unsupplied portion after the existing delivery period, or to extend the delivery period suitably issuing an amendment to the contract. If the supplier fails to deliver the goods and/or perform the services within the contractual delivery period for reasons other than circumstances beyond supplier's control (which will be determined by the purchaser) and the purchaser extends the delivery period, the purchaser will also deduct from the contract price, as liquidated damages, a sum equivalent to 0.5% (half per cent) of the delivered price of the delayed goods or unperformed services for each week of delay or part thereof until actual delivery or performance. The maximum limit of such deduction will, however, be 10% (ten percent) of the contract price of the delayed goods or services.

Further during such delayed period of supply and /or performance, the supplier shall not be entitled to any increase in price and cost on any ground, whatsoever, of the goods and services, supplied during the period of delay.

The purchaser's letter (to the supplier, with copies endorsed to others concerned) extending the delivery period will be subject to the above conditions.

**xi) Warranty Clause: Two Years Onsite Warranty.**

**xii) Dispute Resolution Mechanism**

If any dispute or difference arises between the purchaser and the supplier relating to any matter connected with the contract, the parties shall make every effort to resolve the same amicably by mutual discussions. However, if the parties fail to resolve the dispute or difference by such mutual discussion within 30 days, either the purchaser or the supplier may give notice to the other party of its intention to refer the same to arbitration. The arbitration shall commence thereafter. The arbitration shall be conducted by a sole arbitrator, who will be appointed by the Secretary, ICAR and the procedure to be followed in this respect will be as per the Indian Arbitration and Conciliation Act, 1996. The venue of the arbitration shall be the place from where the contract is issued.

**2. You are also required to fulfil the following conditions and furnish the details as indicated in subsequent paragraphs.**

- a) At the time of awarding the contract, the purchaser reserves the right to increase or decrease by up to 25%, the quantity of goods and services as specified in the list of requirements, without any change in the unit price or other terms and conditions.
- b) Please furnish a certified copy your later ITCC (INCOME TAX CLEARANCE CERTIFICATE).

- c) Please indicate if you are currently registered with any Govt, organization and if registered, furnish all relevant details.
- d) Please state whether business dealings with you presently stand banned by any Government organization and, if so, furnishes relevant details.
- e) A supplier shall not submit more than one quotation for the same set of goods.
- f) The supplier shall at all times indemnify the purchaser, at no cost to the purchaser, against all third party claims of infringement of patent, trademark or industrial design rights arising from the use of the goods or any part thereof, with respect to the goods quoted by the supplier in its offer.
- g) The quotation(s) as well as the contract shall be written in **English language**. All correspondence and other documents pertaining to the quotation(s) and the contract, which the parties exchange, shall also be written in English.

The quotation and all correspondence and documents relating to the quotation exchanged between the bidder and the purchaser may also be written in Hindi language provided that the same is accompanied by an English translation, in which case, for the purpose of interpretation of the quotation, the English translation shall govern.

- h) The contract shall be governed by the laws of India and interpreted in accordance with such laws.
- i) **The quotation/offer shall remain valid for acceptance for a period not less than 90 days after the specified date of opening of the offers.**

3. The quotation shall be sealed in an envelope. The envelope shall be addressed to the Director and it should also bear the tender enquiry no. and the words "**DO NOT OPEN BEFORE 14.10.2015 14:30 Hrs.**" This envelope should then be put inside another envelope, which will also be duly sealed. The outer envelope will bear the full address of the purchaser. The supplier must ensure that its tender (i.e., quotation), duly sealed as above, reaches the purchaser at least one hour before the time and date of opening of tenders. **The supplier may, at its choice, send the tender by registered post or by speed post. Alternatively, the supplier may also hand deliver the tender to the purchaser. In which case the purchaser shall give the supplier a receipt, indicating the time and date of receipt of the tender.**

4. **The tender, which are received late by the purchaser will be ignored. Further, the purchaser does not accept any liability and responsibility for the tenders in case the same are not properly sealed and marked and/or sent as above.**

**5. THE TENDERS WHICH ARE RECEIVED ON TIME (AS PER PARA 3 ABOVE) WILL BE OPENED AT PURCHASER'S OFFICE AT 14:30 HOURS ON 14.10.2015 (DATE)**

6. The purchaser will evaluate and compare the quotations which are substantially responsive i.e., which are properly prepared and signed and meet the required terms, conditions, specification etc. The purchaser will award the contract to the supplier whose quotation will be determined to be responsive and offering the best evaluated price.

7. Notwithstanding the above, the purchaser reserves the right to accept or reject any quotation or annul the tendering process and reject all quotations at any time prior to award of the contract, without assigning any reason, whatsoever, and without incurring any liability or obligation, whatsoever, to the affected tenderer or tenderers.

8. Please submit your quotation accordingly. You shall sign all the pages of your quotation. Your price quotation may be furnished in the format enclosed as Annexure - 1.

You are also required to return this original tender enquiry (all the pages), as it is, duly signed by you on every page, for our record. You may retain a photocopy of this tender enquiry for your record.

Encl: Annexures

-sd-

SENIOR ADMINISTRATIVE OFFIER

## Annexure- 1

### SPECIFICATIONS & OTHER TECHNICAL DETAILS

#### 1) Schematic diagram:

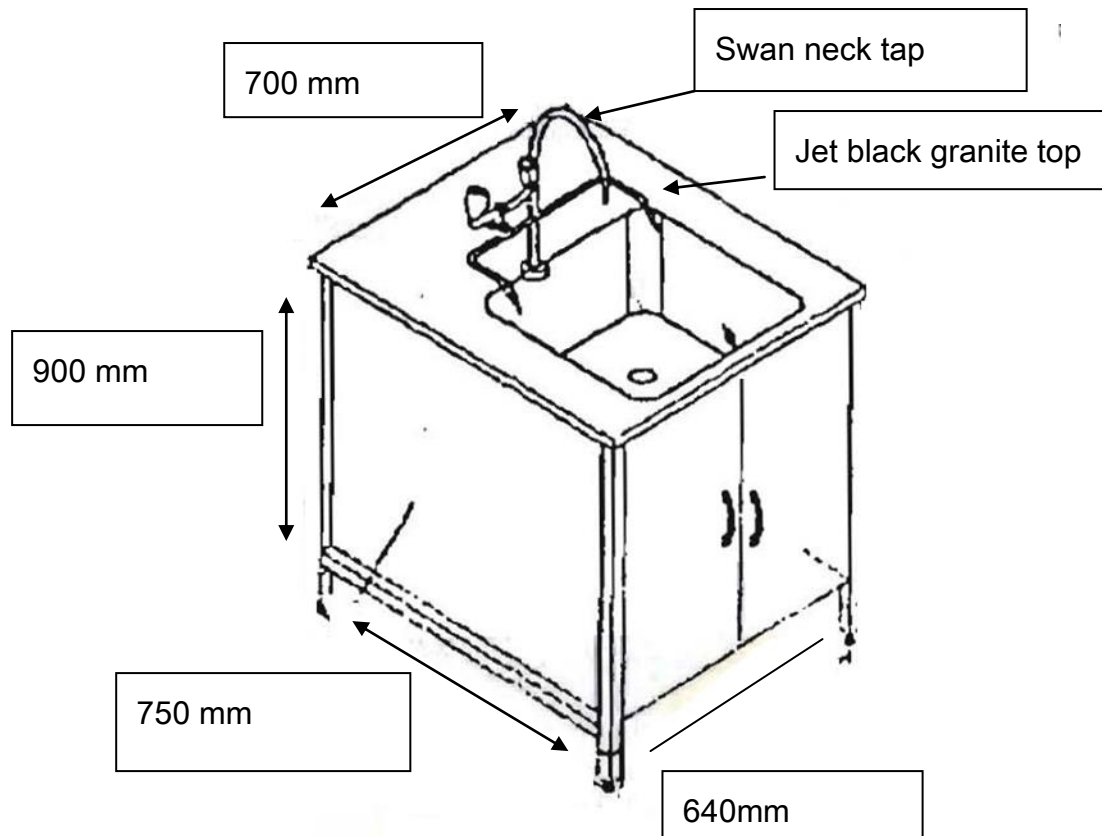

#### 2) Specifications for Modular Table:

The table must be water, corrosion and acid resistant

Dimensions (L x W x H): 640 mm x 700 mm x 900 mm

With 18 mm thick jet black granite top, edges are round profiled, Overhang 25 mm

Sink unit should have 3 way (2 straight + 1Swan neck) water tap made up of brass with Epoxy Powder coating.

Door: 0.8 mm CRCA MS Powder coated double door at front side (Sky Blue).

Sides: 0.8 mm CRCA MS Powder coated (Gray)

Height adjusting bolt at each leg.

#### 3) Specifications for Wash Basin:

Stainless steel wash basin 610 mm x 450 mm x 200 mm

FORMAT OF PRICE QUOTATION

Serial No.	Description of Goods & allied services	Accounting unit	Qty	Quoted unit price in Rs.		Total amount in Rs.
				In Figures	In Words	

Grand Total cost: Rs.....



We agree to supply the above goods and allied services. We confirm that the same will meet the description, specification and other technical details as required in the tender enquiry.

We conform that we agree to all other terms and conditions of your tender enquiry including the terms of delivery, period of delivery and warranty provision. .1.

We have furnished all the information, as required in the tender enquiry and attached the relevant documents.

(In case a tenderer desires to put some additional/modified stipulations, terms and conditions etc. the same may be clearly indicated).

We confirm that our offer will remain valid for acceptance for.....days after the date of opening of tenders.

---

Signature, name and designation of the authorized executive of the tendering firm)

For                      and                      on                      behalf                      of-  
.....

(Name and address of the tendering firm)

(Seal of the tendering firm)

Dated:  
Place: