



भा. कृ. अ. प. - राष्ट्रीय अजैविक स्ट्रेस प्रबंधन संस्थान
मालेगांव, बारामती - 413115, पुणे, महाराष्ट्र, भारत
ICAR - National Institute of Abiotic Stress Management

Malegaon, Baramati- 413115, Pune, Maharashtra, India



F.No:3-79/2015-16

Dated: 3/11/2015

TENDER NOTICE

The Director, ICAR, National Institute of Abiotic Stress Management, Baramati on behalf of the Secretary, Indian Council of Agricultural Research, Krishi Bhawan, New Delhi invites sealed tenders in the prescribed tender form (**Two bid system**) for **supply and Installation of lab tables with basins** from the reputed manufacturers, dealers and suppliers. The details are given below:

Sl.No.	Description	Qty. (Nos.)	EMD
1	Lab tables with basins	4	Rs. 10,000/-

The prescribed tender forms and other details can be availed from this Institute on payment of Rs.1000/- (Non- refundable) by cash or through a crossed demand draft drawn in favour of “**ICARUNIT;NIASM, BARAMATI**” on any working day from 3.11.2015 between 10:30 Hr. to 16:30 Hr. For full details please log on to <http://www.niam.res.in>. Tender form downloaded will also be accepted provided the tenderer should enclose the cost of the tender document of Rs. 1000/- by means of DD.

1. The last date for the sale of tender form is 23.11.2015 up to 1.00 PM noon.
2. The last date of receipt of complete sealed tenders is 23.11.2015 up to 2.00 PM.
3. The process of opening of the tender will be on 23.11.2015 at 2.30 PM.

Sd/-

ADMINISTRATIVE OFFICER
NIASM;BARAMATI

TENDER SCHEDULE TO DOCUMENT No.3-79/15-16

National Institute of Abiotic Stress Management

Malegaon, Baramati – 413115, Pune, MS

INVITATION OF TENDER FOR “**supply and installation of lab tables with basins**”

COST OF THE TENDER DOCUMENT IS RS. 1000/- & E.M. AS SPECIFIED IN THE
TENDER

SALE OF TENDER DOCUMENT FROM 3 -11-2015 FROM 10.30 HRS TO 16.30 HRS ON
ALL WORKING DAYS AT THIS INSTITUTE

LAST DATE OF SALE OF TENDER FORM; 23-11-2015 UPTO 1.00 Noon

LAST DATE AND TIME FOR ACCEPTANCE OF SEALED TENDER DOCUMENT IS ON
23-11-2015 UPTO 2.00 PM

DATE OF OPENING OF TENDER BID WILL BE OPEN ON 23-11-2015 AT 2.30 PM
ONWARDS;

PLACE OF OPENING BIDS IS AT THE CONFERENCE TABLE OF ICAR-NIASM,
MALAGEON, BARAMATI-413115

ADDRESS FOR COMMUNICATION

THE DIRECTOR

NATIONAL INSTITUTE OF ABIOTIC STRESS MANAGEMENT

MALEGAON (KH.)

TAL.-BARAMATI, PUNE- 413115, M.S

Signature of the Bidder

(with firm seal)

TENDER SCHEDULE TO DOCUMENT No. 3-79/2015-16

National Institute of Abiotic Stress Management

Malegaon, Baramati – 413115, Pune, MS

INVITATION OF TENDER FOR **supply and installation of lab tables with basins**

DD NO.

DATE

BANK

AMOUNT

NOTE: The envelope containing the tender as well as all subsequent communications should be addressed/delivered to: DIRECTOR, NIAM, BARAMATI-413115, PUNE, M.S

All the communications must be addressed to the above officer by designation but not by the name

Dear Sirs

On behalf of the Director, NIASM, Baramati I invite you to submit your sealed tender **for supply and installation of lab tables with basins**. The terms and conditions of the tender are enclosed in the Annexure I. You may please submit our bid to this office in the prescribed bid form Annexure II attaching along with all the relevant photo copies of the documents referred in the Annexure I and EMD amount as specified in the tender notice. The EMD may be paid by means of DD drawn in favour of ICAR UNIT; NIASM, BARAMATI.

The complete set of the tender from including annexure in original may please be submitted to office after signing on all pages by the tendered.

Yours faithfully,

-Sd-

Administrative Officer

Signature of the Bidder

(with firm seal)

Tender Document No. 3-79/15-16

National Institute of Abiotic Stress Management

Malegaon, Baramati – 413115, Pune, MS

Terms & Conditions:

1. Tender document

1.1 The non-transferable tender document, in English, may be obtained from the **AO, National Institute of Abiotic Stress Management, Malegaon, Baramati** any working day from the day of tender advertisement..

2. Tenders/Quotations

2.1 Must be sent/submitted in the Office of the **Director, National Institute of Abiotic Stress Management, Malegaon, Baramati** by **23.11.2015 till 02.00 PM.**

2.2 Tenders/Quotations must be written in English. All accompanying technical literature, and correspondence in connection with or arising from a bid shall be in English.

2.3 The price of the item may be quoted in Indian rupees or foreign currency. However, Price quoted in foreign currency must have its conversion price in Indian Rupees, which only will be taken into consideration for comparison purpose.

2.4 The tender forms alongwith the specifications/details can be obtained at the cost of **Rs.1000/-** for each item in cash upto **23.11.2015 at 1:00 PM.** (Except those who are registered with the Central Purchase Organization & National small Industries Corporation (proof should be mandatory enclosed). The tender form can also be downloaded from our website **www.niam.res.in** and submitted alongwith the Earnest money by due-date. Where tender-form is downloaded from website, a demand draft of **Rs 1000/- in favor of ICAR Unit NIASM payable at Baramati** may be enclosed separately as the cost of tender-form.

2.5 Tenders/Quotations must be addressed to:-The Director

ICAR-Institute of Abiotic Stress Management, Malegaon, Baramati-413115

3. Late Tenders

3.1 Any tender/Quotations received by the Purchaser after the deadline for submission of tender/Quotations will be rejected and returned unopened to the Tenderer.

4. Earnest Money

4.1 Bidders have to furnish Bid Security/earnest money worth as mentioned in tender notice in shape of DD in favour of **ICAR-Unit-NIASM payable at Baramati** along with the bid(s) from a Nationalized Bank. The Earnest Money is required to protect the Purchaser against the risk of Tenderer's conduct, which would warrant the security's forfeiture.

4.2 The Earnest Money shall be in one of the following forms:

- a) A bank guarantee issued by a reputed bank located in the country and valid for 6 (six) months.
- b) A Bank Draft/ FDR payable to "ICAR- Unit- NIASM, Baramati".

4.3 Any tender not accompanied by Earnest Money will be straight way rejected.

4.4 Unsuccessful Tenderer's Earnest Money will be discharged or returned as promptly as possible

4.5 The Earnest Money may be forfeited:

- a) If a Tenderer/bidder withdraws its tender during the period of tender validity specified by the Tenderer on the Tender Form; or
- b) In case of a successful Tenderer/bidder, if they fails to furnish Security Deposit.

5. Performance Security

5.1 Within thirty (30) days, the successful tenderer shall furnish to the purchaser the Security Deposit equivalent to 10% of the purchase value.

5.2 The Security Deposit shall be in one of the following forms: (a) Bank Guarantee, issued by a reputed bank or a FDR/Demand Draft payable to **"ICAR- Unit –NIASM, Baramati"**.

5.3 Failure of the successful Tenderer/bidder to sign the contract and/or furnish the Security Deposit shall constitute sufficient grounds for the annulment of the award and forfeiture of the Earnest Money, in which event the Purchaser may make the award to the next lowest evaluated Tenderer or call for new tenders.

5.4 The Security Deposit will be discharged by the purchaser and returned to the Supplier following the date of completion of the Supplier's performance obligations under the contract, including any warranty obligations after receiving agreement letter.

6. Period of Validity of Tenders/quotations

6.1 Validity of Tenders/quotations shall be 180 days after the date of tender opening. A tender valid for a shorter period shall be rejected by the Purchaser as non-responsive.

7. Delivery and Documents

7.1 Delivery shall be made by the Supplier within 30 days from the date of placing order which may be extended at the discretion of the competent authority.

7.2 Documents to be submitted by Supplier are specified in technical specifications.

8. Transportation

8.1 The transportation costs etc. to transport the equipment to the consignee's place shall be borne by the tenderer.

9. Dispute Resolution Mechanism: If any dispute or difference arises between the purchaser and the supplier relating to any matter connected with the contract, the parties shall make every effort to resolve the same amicably by mutual discussions. However, if the parties fail to resolve the dispute or difference by such mutual discussion within 30 days, either the purchaser or the supplier may give notice to the other party of its intention to refer the same to arbitration. The arbitration shall commence thereafter. The arbitration shall be conducted by a sole arbitrator, who will be appointed by the Secretary, ICAR and the procedure to be followed in this respect will be as per the Indian Arbitration and Conciliation Act, 1996. The venue of the arbitration shall be the place from where the contract is issued.

10. You are also required to fulfill the following conditions and furnish the details as indicated in subsequent paragraphs.

- a) At the time of awarding the contract/order, the purchaser reserves the right to increase or decrease the quantity of goods, without any change in the unit price or other terms & conditions.
- b) Please indicate if you are currently registered with any Govt. organization and if registered, furnish all relevant details.
- c) Please states whether business dealings with you presently stand banned by any Government organization and if so, furnish relevant details.
- d) A supplier shall not submit more than one quotation for the same set of goods.
- e) The supplier shall at all times indemnify the purchaser, at no cost to the purchaser, against all third party claims of infringement of patent, trademark or industrial design rights arising from the use of the goods or any part thereof, with respect to the goods quoted by the supplier in its offer.
- f) The quotation (s) as well as the contract shall be written in Hindi/English language.
- g) The contract shall be governed by the laws of India and interpreted in accordance with such laws.
- h) The Director, NIASM, Baramati reserves the right to reject any tender in part or full without assigning any reason thereof.

11.2 The supplier warrants that the System and services provided under the contract are based on new, unused, latest, most recent or current models, and that they incorporate all recent improvements in design and materials unless provided otherwise in the contract. The supplier further warrants that all services/systems supplied under this contract shall have no defect, arising from design, materials, or workmanship except when the design and/or material is required by the purchaser's specifications or from any act or omission of the Supplier, that may develop under normal use of the supplied system in the conditions prevailing in the Board.

11.3 The purchaser shall promptly notify the supplier in writing of any claims arising under this warranty.

11.4 Upon receipt of such notice, the supplier shall immediately repair or replace the defective system without any cost to the purchaser.

11.5 If the supplier, having been notified, fails to remedy the defect (s) within a reasonable period, the

Purchaser may proceed to take such remedial action as may be necessary, at the supplier's risk and expense and without prejudice to any other rights which the purchaser may have against the supplier under the contract.

Annexure- I:

SPECIFICATIONS & OTHER TECHNICAL DETAILS

1) Schematic diagram:

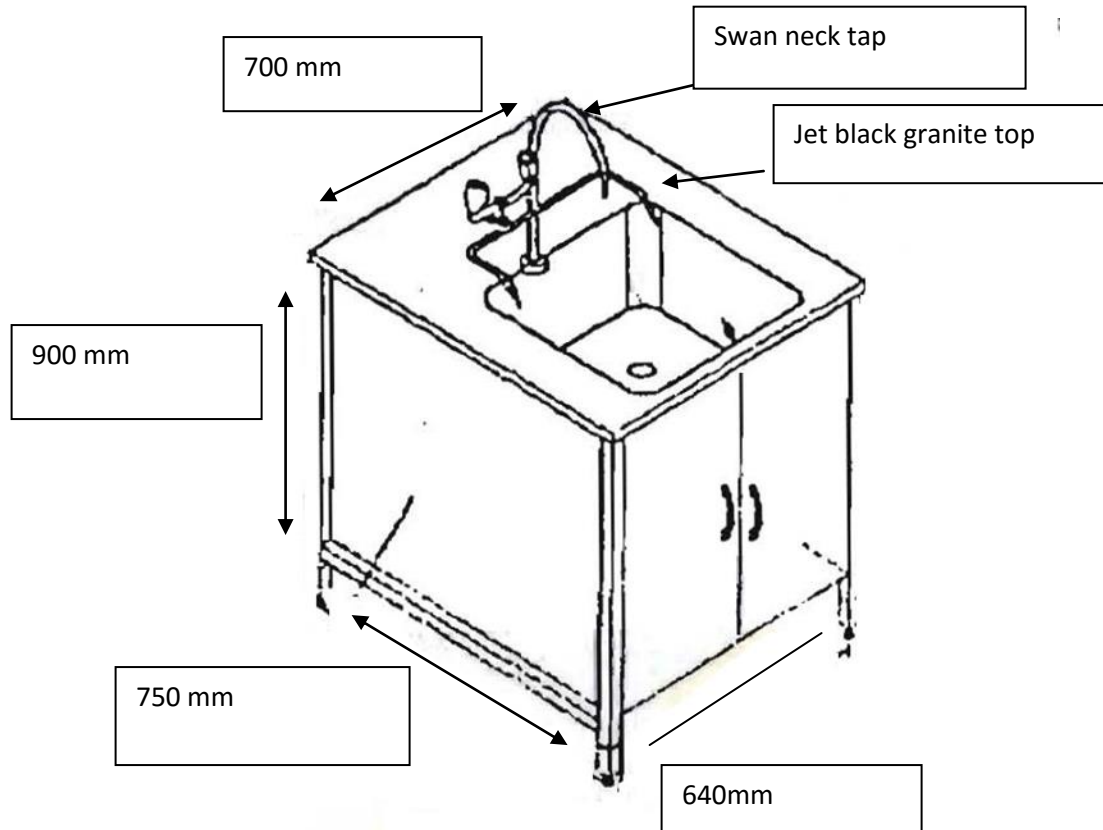

2) Specifications for Modular Table:

The table must be water, corrosion and acid resistant

Dimensions (L x W x H): 640 mm x 700 mm x 900 mm

With 18 mm thick jet black granite top, edges are round profiled, Overhang 25 mm

Sink unit should have 3 way (2 straight + 1 Swan neck) water tap made up of brass with Epoxy Powder coating.

Door: 0.8 mm CRCA MS Powder coated double door at front side (Sky Blue).

Sides: 0.8 mm CRCA MS Powder coated (Gray)

Height adjusting bolt at each leg.

3) Specifications for Wash Basin:

Stainless steel wash basin 610 mm x 450 mm x 200 mm

Annexure II

Financial Bid

Sl.No.	Description of Goods	Accounting unit & qty.	Ex factory/Ex warehouse/Ex showroom off the shelf (A)	Vat (B)	Total Price (A+B)	Service Tax payable if contract is awarded

Total bid price: In figures.....

In Words.....

Place :.....

Date:

Note: In case of discrepancy between unit price and total price, the unit price shall prevail

**Signature of the Bidder
(with firm seal)**